

**RSR/RPB SERIES  
FIREPROOF INTUMESCENT AND SMOKE SEAL FOR FIREPROOF DOORS**

RSR/RPB series flexible fireproof intumescent and smoke seal is a kind of high temperature extruded silicone gasket compounding with RPB series intumescent seals.

- Intumescent material expansion ratio: 20-30times
- Demonstrates extremely low closing force
- Impervious to fungus and mildew
- Function: Seal gaps to prevent smoke weather dust fire and heat
- Product comes with strong self-adhesive

Color is optional



Windproof



Dustproof



Smokeproof



Fireproofing

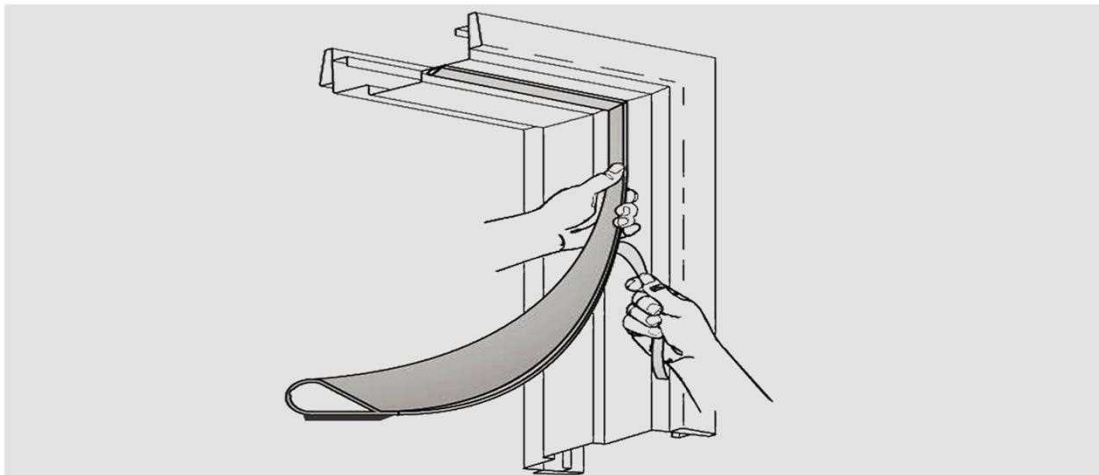

Graphite fireproof core

RSR/RPB can be used on fireproof doors where require both fire and smoke protection, it helps to slow the passage of smoke weather dust fire and heat.



Graphite intumescent seal composite material



High temperature extruded silicone gasket

Raw materials contain high grade graphite and silicone for excellent fire preventing performance.

**RSR SERIES**  
**RSR/RPB SERIES SIZE CHART**

